

FIGHTER

**SPECIFICATION
SHEET**

4X2

1627

9 SPEED MANUAL

FM65/7..F



199KW • 16000KG GVM • 32000 GCM



**DRIVER'S AIR BAG
HILL START ASSIST
ISRI DRIVER'S SEAT
30,000KM SERVICE INTERVALS**

SPECIFICATIONS

MODEL:		WHEEL BASE
FM65FH2RFAF	swb 9 Speed	4280mm
FM65FS2RFAF	xxlwb 9 Speed	6500mm
FM67FM2RFAF	xlwb 9 Speed	5550mm
FM67FS2RFAF	xxlwb 9 Speed	6500mm

ENGINE

Mitsubishi FUSO 6M60-9AT2 Diesel (ADR 80/03-Euro V)

Configuration:	6 Cyl. In-line OHC, 4-Valve
Type:	Turbocharged with Air to Air Intercooler, PCV & Common Rail Fuel System, SCR after-treatment system (BlueTec)
Displacement:	7545cc
Bore:	118mm
Stroke:	115mm
Power (ECE R85-00):	199kW @ 2500 rpm
Torque (ECE R85-00):	784Nm @ 1100-2400 rpm
Maximum Engine Speed:	2900 rpm
Compression Ratio:	16.0:1
Oil Cooler:	Plate Type, Water Cooled
Air Cleaner:	Dual Element Cyclonic with Vertical Intake & Air Restriction Indicator

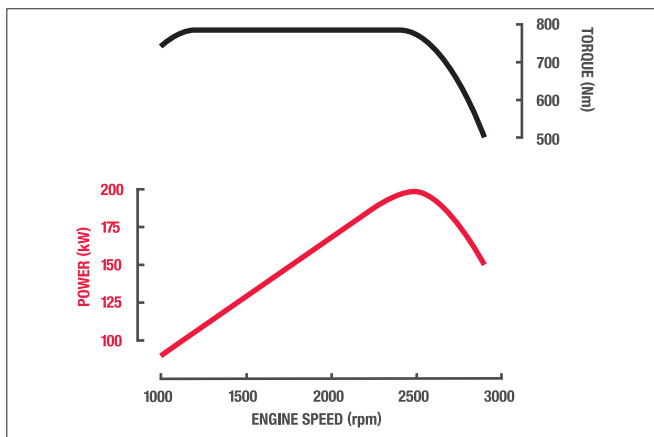

FUEL

Injection System:	DENSO Common Rail System
Governor:	Electronic
Tank Type:	Rectangular Steel
Fuel Capacity:- FM67 FM65FS	300 Litres
- FM65FH	200 Litres
Fuel Cooler:	Fitted
AdBlue Exhaust Fluid Capacity:	40 Litres

COOLING

Fan:	540mm dia. 10 Blades
Fan Drive:	Thermo Modulated
Radiator:	Corrugated Fin with Expansion Tank

ELECTRICAL

Voltage:	24V Negative Earth
Alternator Capacity:	24V-80 amp
Starter Capacity:	24V-5.0kW
Battery Capacity:	2x12V, 65Ah/5hr
Headlamp - Type:	Halogen
- Capacity:	Low Beam 2x70W High Beam 2x70W

CLUTCH

Mitsubishi FUSO C7M38

Disc Diameter:	380mm
Type:	Single Dry Plate
Operation:	Air Assisted Hydraulic

TRANSMISSION

Eaton ES-11109 (Fuso Code M060S9)

No. of Speeds:	9
Synchromesh:	1L~4H
Ratios - Low:	Low High
- 1st:	12.64 2.48
- 2nd:	8.81 1.85
- 3rd:	6.55 1.34
- 4th:	4.77 1.00
- Rev.	13.21
PTO Opening:	LH Side & Rear

PROPELLER SHAFT

Type:	P12
Universal Joint:	Needle Roller

FRONT AXLE

Mitsubishi FUSO F650T

Type:	Reverse Elliot 'I' Beam
Capacity:	6300kg

REAR AXLE

Mitsubishi FUSO R080T/D10H

Type:	Full Floating Hypoid
Capacity:	10800kg
Ratio: - FM65	4.625:1
- FM67	4.222:1

STEERING

Type:	Integral Power Assisted Ball and Nut
Ratio:	22.4:1
Steering Column:	Tilt/Telescopic Adjustable with Lock



Full 90 degree door opening for easy access. Passenger door has transom window for improved visibility.



The ISRI air suspended driver's seat provides high levels of comfort and support.



Spacious cab with air-conditioning, CD player, cruise control, electric windows and keyless central locking.

GVM:
16000kg
16000kg
16000kg
16000kg

GCM:
32000kg
32000kg } Steel Rear Suspension
32000kg
32000kg } Air Rear Suspension

BRAKES

Type:	Full Air, Dual Circuit, Mitsubishi FUSO Taper Roller, Automatic Brake Adjustment, ABS with ASR (Anti Slip Regulator)
Size - Front:	410x150mm
- Rear:	410x200mm
Park Brake:	Rear Wheel Spring Actuated
Auxiliary:	Exhaust Brake
Compressor:	Water Cooled, 340cc Single Cyl.
Air Dryer Model:	MD4

FRONT SUSPENSION

Type:	Parabolic Leaf
Size:	1400x80mm Leaves
Shock Absorbers:	Double Acting

REAR SUSPENSION (FM65 - STEEL)

Type:	Semi-Elliptic Leaf
Size:	1400x80mm Leaves
Auxiliary:	960x80mm Leaves

REAR SUSPENSION (FM67 - AIR)

Type:	Trailing Arm with Air Dump Control
RFCN:	RF2043
Air Spring:	2x250mm dia.
Trailing Arm:	(643+390)x80x35mm-2 Leaves
Capacity at Ground:	10000kg total
Shock Absorbers:	Double Acting

CHASSIS

Type:	Parallel Channel
Size:	280x90x8.0mm
Width:	841mm
Tensile Strength:	540Mpa

WHEELS & TYRES

Wheel - Type:	7, Single Piece Disc
- Size:	22.5x8.25DC-165-13t
- Stud Pattern:	10x335mm PCD
Tyre - Size:	
FM65	11R22.5 148/145L Traction Tread to Rear
FM67	275/70R22.5 148/145L
Spare Tyre Carrier:	Provided

MASS (KG - ESTIMATED)*

Model	Front	Rear	Total
FM65FH2RFAF	2925	1925	4850
FM65FS2RFAF	3065	2045	5510
FM67FM2RFAF	3000	1930	4930
FM67FS2RFAF	3055	2010	5065

Note: Mass (est.) includes oil and water but excludes spare wheel, tools & fuel
* Weights provided are subject to 3.5% variation (+/-)

INSTRUMENTS

Gauges:	Speedometer with Odometer Tachometer Air Pressure (2) Fuel Level Water Temperature
Colour Information Display	Fuel Consumption Service Indicators Hour Meter and Tripmeter
Warning Lamps:	ABS ASR Turn Signal High Beam Exhaust Brake Hill Start Assist Oil Level Ad Blue Low Fuel Low Park Brake Alternator Oil Filter Blockage Engine Control / Cruise Control (ECU) Air Filter Restriction Fuel Filter Water Contamination Door Opening Cab Tilt Lock High/Low Gear Range
Warning Lamp/Buzzer:	Air Pressure Oil Pressure Engine Overheat / Low Coolant Level

CAB FEATURES

All Steel Forward Control	
Type:	Manual Tilt 44 deg.
Mounting:	Hydroelastic Susp. 4 Point
Colour:	Natural White
Interior:	Fully Trimmed
Windscreen:	Laminated Tinted
Windscreen Wipers:	2 Speed + Intermittent Cycle with Integrated Washer Nozzles
Door:	90 degree Opening Angle
Steering Column:	Telescopic & Tilt
Rear Vision Mirrors	Remote / Heated with Convex Spotter (Both Sides)
Seating Capacity:	3
Seat Belts:	2 ELR Lap Sash, 1 Lap
Seats - Driver:	ISRI Air Suspension with Height, Tilt and Dampening Adjustment Integral Headrest and Fabric Trim Low Back with Fabric Trim Forward Folding Fixed Base Reclining Integral Headrest and Fabric Trim
- Centre:	
- LH:	

MAX. LOADING			
Model	Front	Rear	Total
FM65	6000kg	10000kg	16000kg
FM67	6000kg	10000kg	16000kg



The new dash has a colour display that shows important information such as average and current fuel consumption, oil level and service replacement requirements.

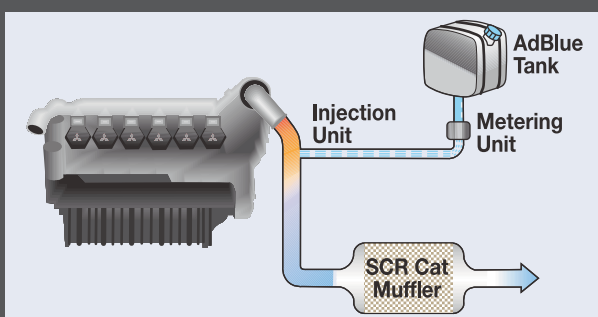

SCR is a simple system that allows the engine to be tuned for optimal combustion and injects AdBlue into the exhaust to reduce emissions.

SPECIFICATIONS

STANDARD FEATURES

Driving

Driver's Air Bag and Seat Belt Pre-tensioners
Hill Start System
ASR (Traction Control)
Keyless Central Locking
Electric Windows
Cruise Control
LH Transom Window
24V Accessory Power Outlet / Cigar Lighter
Air Conditioner / Heater / Demister
Radio / CD Player
Cup Holders (4)
Rear Quarter Glass
Fluorescent Cabin Lamp and Interior Reading Lamps
Engine Idle Speed Control

Storage

Centre Seat Storage Console
LH Seat Storage Tray
Rear Bunk Storage Pocket
Dash Storage Tray 2 DIN Glove Compartment
1 Single & 1 Double DIN Slot for Accessories
Overhead Storage Pocket with Lid
RH Door Storage Pocket

Cab: External

Roof Mounting Points (max. static load 70kg)
Front End-Outline Marker Lamps

Chassis

Tool Kit and Chassis Mounted Tool Box
Reverse Warning Buzzer

Service

30,000km Intervals or 12 Months

DIMENSIONS (MM)

		Wb = Wheel Base			
		H Wb Steel	S Wb Steel	M Wb Air	S Wb Air
Width	Front Fender:	2450	2450	2450	2450
	Rear Axle:	2470	2470	2470	2470
	Front Track:	1925	1925	1925	1925
	Rear Track:	1850	1850	1850	1850
	Frame:	841	841	841	841
Length A	Overall:	7455	10695	9325	10695
	C Front Overhang:	1245	1245	1245	1245
	D Wheelbase:	4280	6500	5550	6500
	G Front Axle to Rear of Cab:	745	745	745	745
	H Rear of Cab to Rear of Engine Cover:	130	130	130	130
	I Frame, Rear of Engine Cover to Rear Axle:	3405	5625	4675	5625
	J Frame, Rear Axle to End:	1930	2950	2530	2950
Height	N Overall:	2885	2885	2835	2835
	P Cab to Ground:	2680	2680	2630	2630
	Q Cab to Frame:	1669	1669	1669	1669
	R Rear Frame to Ground:				
	- FM65:	1074	1072		
	- FM67 Suspension - Inflated:			969	969
	- Deflated:			922	922

PERFORMANCE - (CALCULATED-PAVED ROAD)

	*100	*100	*100	*100
Electronically Speed Limited to (km/h)	*100	*100	*100	*100
Engine Speed at 100km/hr (rpm)	2428	2428	2428	2428
Gradeability** at Rated GVM:	53%	53%	53%	53%
Gradeability** at Rated GCM:	23%	23%	23%	23%
Turning Circle (kerb to kerb):	14.6m	21.4m	18.4m	21.4m
* Conforms to ADR65/..				
** This is Theoretical Performance (it may vary under different conditions).				

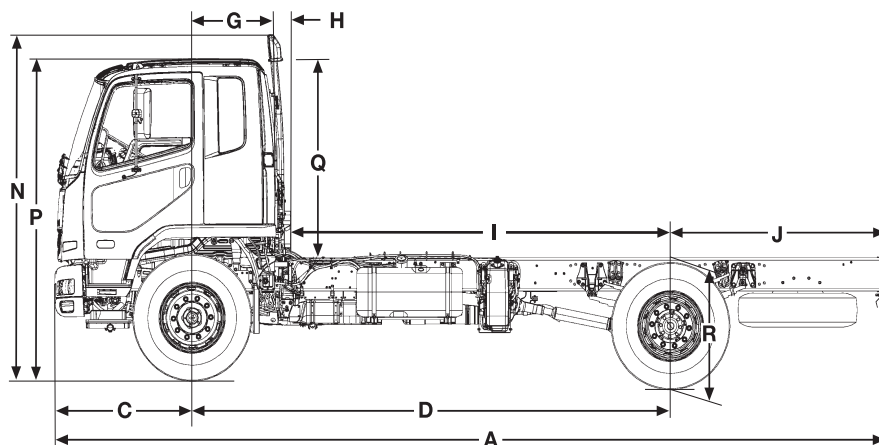

WARRANTY

3 YEAR & 3 YEAR

Basic/Powertrain

3 Years, 200,000kms or 4,000 operating hours
(whichever comes first)
3 Years Cab Perforation/Anti Corrosion

Note: Chassis reinforcement must be utilised for Tipper/Demountable type body configurations.

To conform with ADR 13/00 (lighting requirements) the following must be adhered to at body installation.

- If other than a flat type or tipper body is fitted, rear end out-line marker lamps must be installed.
- If overall length exceeds 6.0 metres, side reflectors must be installed.
- If overall length exceeds 7.5 metres, side marker lamps must be installed.

To conform with ADR 42/04 (General Safety), rear wheel guards must be fitted to the vehicle.

Call 1300 426 812 or visit fuso.com.au

