

FIGHTER
SPECIFICATION
SHEET

4X2

1227

AIR SUSPENSION

FK65F/C



199kW • 12000kg GVM • 20000 GCM • LOW CHASSIS HEIGHT



DRIVER'S AIR BAG
HILL START ASSIST
ISRI DRIVER'S SEAT
30,000KM SERVICE INTERVALS

SPECIFICATIONS

MODEL:
FK65FLZ2RFAC lwb
FK65FMZ2RFAC xlwb

WHEEL BASE
5210mm
5540mm

ENGINE

Mitsubishi FUSO 6M60-9AT2 Diesel (ADR 80/03-Euro V)

Configuration:	6 Cyl. In-line OHC, 4-Valve
Type:	Turbocharged with Air to Air Intercooler, PCV & Common Rail Fuel System, SCR after-treatment system (BlueTec)
Displacement:	7545cc
Bore:	118mm
Stroke:	115mm
Power (ECE R85-00):	199kW @ 2500 rpm
Torque (ECE R85-00):	784Nm @ 1100-2400 rpm
Maximum Engine Speed:	2900 rpm
Compression Ratio:	16.0:1
Oil Cooler:	Plate Type, Water Cooled
Air Cleaner:	Dual Element Cyclonic with Vertical Intake & Air Restriction Indicator

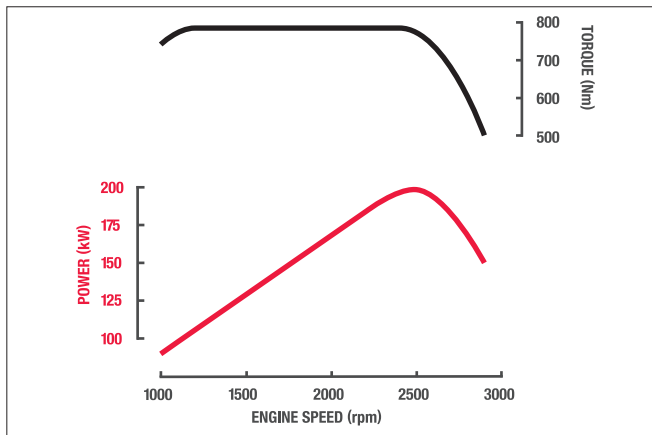

FUEL

Injection System:	DENSO Common Rail System
Governor:	Electronic
Tank Type:	Rectangular Steel
Fuel Capacity:	200 Litres
Fuel Cooler:	Fitted
AdBlue Exhaust Fluid Capacity:	22 Litres

COOLING

Fan:	540mm dia. 10 Blades
Fan Drive:	Thermo Modulated
Radiator:	Corrugated Fin with Expansion Tank

ELECTRICAL

Voltage:	24V Negative Earth
Alternator Capacity:	24V-80 amp
Starter Capacity:	24V-5.0kW
Battery Capacity:	2x12V, 65Ah/5hr
Headlamp - Type:	Halogen
- Capacity:	Low Beam 2x70W High Beam 2x70W

CLUTCH

Mitsubishi FUSO C7M38	
Disc Diameter:	380mm
Type:	Single Dry Plate
Operation:	Air Assisted Hydraulic

TRANSMISSION

Mitsubishi FUSO M070S6-0D	
No. of Speeds:	6 with Air Assisted Gearshift
Synchromesh:	2nd-6th
Ratios - 1st:	6.807
- 2nd:	4.172
- 3rd:	2.396
- 4th:	1.504
- 5th:	1.000
- 6th:	0.774
- Rev:	6.807
PTO Opening:	LH Side

PROPELLER SHAFT

Type:	P10
Universal Joint:	Needle Roller

FRONT AXLE

Mitsubishi FUSO F500T	
Type:	Reverse Elliot 'I' Beam
Capacity:	5000kg

REAR AXLE

Mitsubishi FUSO R052T/D052H	
Type:	Full Floating Hypoid
Capacity:	9500kg
Ratio:	4.625:1

STEERING

Type:	Integral Power Assisted Ball and Nut
Ratio:	18.0~19.8:1
Steering Column:	Tilt/Telescopic Adjustable with Lock

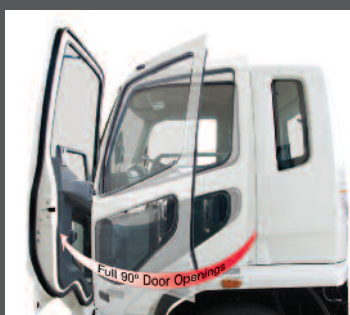

Full 90 degree door opening for easy access. Passenger door has transom window for improved visibility.



The ISRI air suspended driver's seat provides high levels of comfort and support.



Spacious cab with air-conditioning, CD player, cruise control, electric windows and keyless central locking.

GVM:
12000kg
12000kg

GCM:
20000kg
20000kg

BRAKES

Type:	Full Air, Dual Circuit, Mitsubishi FUSO Taper Roller, Automatic Brake Adjustment, ABS with ASR (Anti Slip Regulator)
Size - Front:	370x150mm
- Rear:	370x150mm
Park Brake:	Rear Wheel Spring Actuated
Auxiliary:	Exhaust Brake
Compressor:	Water Cooled, 340cc Single Cyl.
Air Dryer Model:	DU5

FRONT SUSPENSION

Type:	Parabolic Leaf
Size:	1300x70mm Leaves
Shock Absorbers:	Double Acting

REAR SUSPENSION (AIR)

Type:	Trailing Arm with Air Dump Control
Air Spring:	2x270mm dia.
Trailing Arm:	(683+424)x80x35mm-2 Leaves
Shock Absorbers:	Double Acting

CHASSIS

Type:	Parallel Channel with Reinforcement
Size:	230x80x8.0mm
Width:	844mm
Tensile Strength:	540Mpa

WHEELS & TYRES

Wheel - Type:	7, Single Piece Disc
- Size:	19.5x6.75DC-147-13t
- Stud Pattern:	8x285mm PCD
Tyre - Size:	265/70R19.5 140/138M
Spare Tyre Carrier:	Provided

MASS (KG - ESTIMATED)*

Model	Front	Rear	Total
FK65FLZ2RFAC	2485	1530	4015
FK65FMZ2RFAC	2515	1515	4030

Note: Mass (est.) includes oil and water but excludes spare wheel, tools & fuel

*Weights provided are subject to 3.5% variation (+/-)

INSTRUMENTS

Gauges:	Speedometer with Odometer Tachometer Air Pressure (2) Fuel Level Water Temperature
Colour Information Display	Fuel Consumption Service Indicators Hour Meter and Tripmeter
Warning Lamps:	ABS ASR Turn Signal High Beam Exhaust Brake Hill Start Assist Oil Level Ad Blue Low Fuel Low Park Brake Alternator Oil Filter Blockage Engine Control / Cruise Control (ECU) Air Filter Restriction Fuel Filter Water Contamination Door Opening Cab Tilt Lock
Warning Lamp/Buzzer:	Air Pressure Oil Pressure Engine Overheat / Low Coolant Level

CAB FEATURES

All Steel Forward Control	
Type:	Manual Tilt 44 deg.
Mounting:	Hydroelastic Susp. 4 Point
Colour:	Natural White
Interior:	Fully Trimmed
Windscreen:	Laminated Tinted
Windscreen Wipers:	2 Speed + Intermittent Cycle with Integrated Washer Nozzles
Door:	90 degree Opening Angle
Steering Column:	Telescopic & Tilt
Rear Vision Mirrors	Remote / Heated with Convex Spotter (Both Sides)
Seating Capacity:	3
Seat Belts:	2 ELR Lap Sash, 1 Lap
Seats - Driver:	ISRI Air Suspension with Height, Tilt and Dampening Adjustment Integral Headrest and Fabric Trim Low Back with Fabric Trim Forward Folding
- Centre:	Fixed Base Reclining Integral Headrest and Fabric Trim
- LH:	Fixed Base Reclining Integral Headrest and Fabric Trim

MAX. LOADING		
Front	Rear	Total
5000kg	9200kg	12000kg



The new dash has a colour display that shows important information such as average and current fuel consumption, oil level and service replacement requirements.

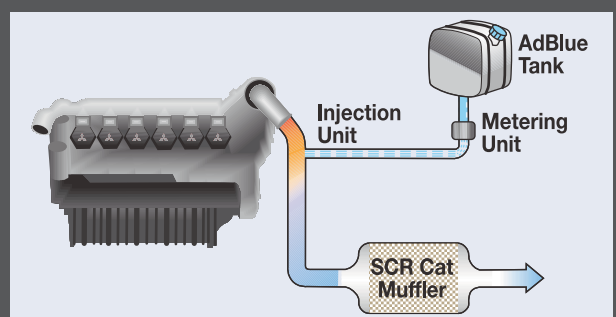

SCR is a simple system that allows the engine to be tuned for optimal combustion and injects AdBlue into the exhaust to reduce emissions.

SPECIFICATIONS

STANDARD FEATURES

Driving

Driver's Air Bag and Seat Belt Pre-tensioners
Hill Start System
ASR (Traction Control)
Keyless Central Locking
Electric Windows
Cruise Control
LH Transom Window
24V Accessory Power Outlet / Cigar Lighter
Air Conditioner / Heater / Demister
Radio / CD Player
Cup Holders (4)
Rear Quarter Glass
Fluorescent Cabin Lamp and Interior Reading Lamps
Engine Idle Speed Control

Storage

Centre Seat Storage Console
LH Seat Storage Tray
Rear Bunk Storage Pocket
Dash Storage Tray 2 DIN Glove Compartment
1 Single & 1 Double DIN Slot for Accessories
Overhead Storage Pocket with Lid
RH Door Storage Pocket

Cab: External

Roof Mounting Points (max. static load 70kg)
Front End-Outline Marker Lamps

Chassis

Tool Kit and Chassis Mounted Tool Box
Reverse Warning Buzzer

Service

30,000km Intervals or 12 Months

DIMENSIONS (MM)

Wb = Wheel Base		L Wb	M Wb
Width	Front Fender:	2170	2170
	Rear Axle:	2270	2270
	Front Track:	1780	1780
	Rear Track:	1710	1710
	Frame:	844	844
Length A	Overall:	8645	9075
	C Front Overhang:	1135	1135
	D Wheelbase:	5210	5540
	G Front Axle to Rear of Cab:	855	855
	H Rear of Cab to Rear of Engine Cover:	130	130
	I Frame, Rear of Engine Cover to Rear Axle:	4225	4555
	J Frame, Rear Axle to End:	2300	2400
Height N	Overall:	2730	2730
	P Cab to Ground:	2524	2525
	Q Cab to Frame:	1669	1669
	R Rear Frame to Ground: - Inflated - Deflated	858 802	858 802

PERFORMANCE - (CALCULATED-PAVED ROAD)

Engine Speed at 100km/hr (top gear) 2249rpm		
Road Speed (km/h) at Max. Engine Speed:	128	128
Gradeability* at Rated GVM:	46%	46%
Gradeability* at Rated GCM:	25%	25%
Turning Circle (kerb to kerb):	18.2m	19.4m

* This is Theoretical Performance (it may vary under different conditions).

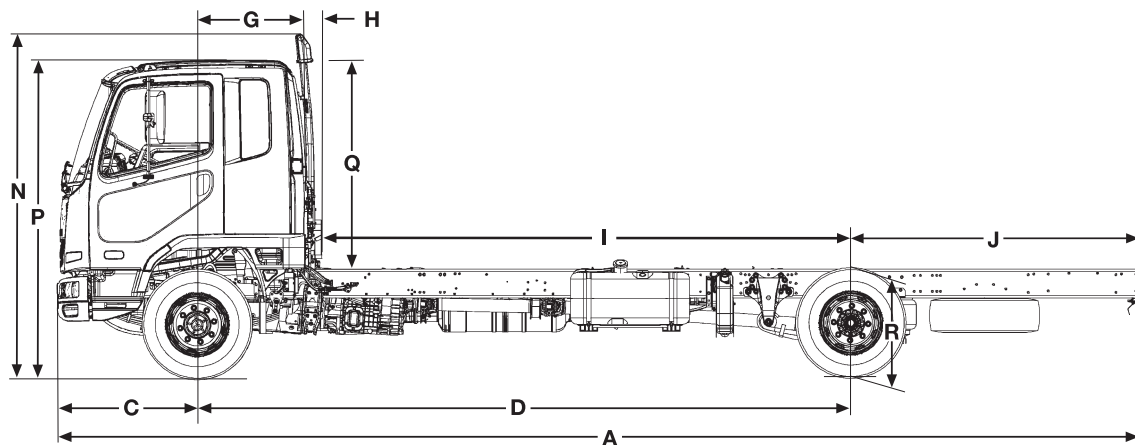

Note: Chassis reinforcement must be utilised for Tipper/Demountable type body configurations.

To conform with ADR 13/00 and 14/02 (lighting/mirror requirements) the following must be adhered to at body installation.

- If other than a flat type or tipper body is fitted, rear end out-line marker lamps must be installed.
- If overall length exceeds 6.0 metres, side reflectors must be installed.
- If overall length exceeds 7.5 metres, side marker lamps must be installed.
- If overall width is less than 2.4 metres, the mirrors must be modified to project not more than 230mm.

To conform with ADR 42/04 (General Safety), rear wheel guards must be fitted to the vehicle.

WARRANTY

3 YEAR & 3 YEAR

Basic/Powertrain

3 Years, 150,000kms or 3,000 operating hours
(whichever comes first)
3 Years Cab Perforation/Anti Corrosion

Call 1300 426 812 or visit fuso.com.au

