

CANTER

The 'Not So Squeezy' Performer



FE 2.0 4x2 Diesel

FE83D

110kW • 471Nm • 4500kg GVM • 8000kg GCM • FRONT & REAR DISC BRAKES • ABS



Optional weight upgrade to 5600kg GVM.

www.fuso.com.au

SPECIFICATIONS

MODEL: FE83DC4SRFAB swb
FE83DE4SRFAB mwb

WHEELBASE: 2750mm
3350mm

ENGINE

Mitsubishi FUSO 4M50-3AT7 Diesel (ADR 80/02)

Configuration: 4 Cyl. In-line DOHC, 4 Valve
Type: Turbocharged & Air to Air Intercooler,
EGR, PCV & Quick Heat Glow Plugs
Catalytic Converter
Displacement: 4899cc
Bore x Stroke: 114 x 120mm
Power (ECE R85-00): 110kW @ 2700 rpm
Torque (ECE R85-00): 471Nm @ 1600 rpm
(Limited to 382Nm in 1st & Rev. Gear)
Maximum Engine Speed: 2900 rpm
Compression Ratio: 17.5:1
Oil Cooler: Plate Type, Water Cooled
Air Cleaner: Dry Paper Element with Vertical Intake

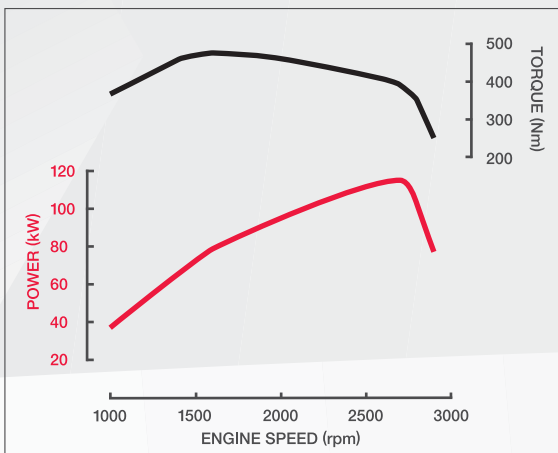

FUEL

Pump: BOSCH Common Rail System
Governor: Electronic
Filtration: Main Filter with Water Separator
Fuel Capacity: 100 Litres with Locking Fuel Cap

COOLING

Fan: 500mm dia. 8 Blades
Fan Drive: Thermo Modulated
Radiator: Corrugated Fin with Expansion Tank

ELECTRICAL

Voltage: 12V Negative Earth
Alternator Capacity: 12V-100 amp
Starter Capacity: 12V-3.0kW
Battery Capacity: 2x12V, 88Ah/5hr in Parallel
Headlamp: 2x60/55W Halogen

CLUTCH

Mitsubishi FUSO C5W33

Disc Diameter: 325mm
Type: Single Dry Plate
Operation: Hydraulic with Direct Power Cylinder

TRANSMISSION

Mitsubishi FUSO M036S5

No. of Speeds: 5 with In-Dash Gearshift Control
Synchronesh: 2nd-5th
Ratios - 1st: 5.175
- 2nd: 2.913
- 3rd: 1.682
- 4th: 1.000
- 5th: 0.715
- Rev. 5.175
PTO Opening: LH Side

PROPELLER SHAFT

Type: P3
Universal Joint: Needle Roller

FRONT AXLE

Type: Reverse Elliot 'I' Beam
Capacity: 2300kg

REAR AXLE

Mitsubishi FUSO D033H

Type: Full Floating Hypoid
Capacity: 3300kg
Ratio: 4.444:1

STEERING

Type: Integral Power Assisted Ball & Nut
Ratio: 22.6:1
Steering Column: Tilt/Telescopic Adjustable with Lock

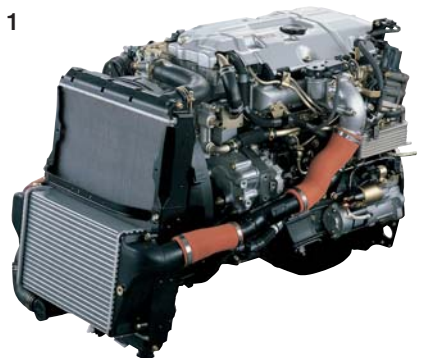

GVM: 4500kg
4500kg

GCM: 8000kg
8000kg

Optional: GVM: 5600kg
GVM: 5600kg



BRAKES

Type: Ventilated Disc, Dual Caliper
Hydraulic Dual Circuit with ABS
Size - Front: 235x40mm
- Rear: 235x40mm
Park Brake: Transmission Mounted
Auxiliary: Exhaust Brake
Vacuum Reservoir Capacity: 4.0 Litres

FRONT SUSPENSION

Type: Parabolic Leaf with Stabiliser Bar
Size: 1200x70mm Leaves
Shock Absorbers: Double Acting

REAR SUSPENSION

Type: Semi-Elliptic Leaf with Stabiliser Bar
Size: 1250x70mm Leaves
Auxiliary: 990x70mm Leaves
Shock Absorbers: Double Acting

CHASSIS

Type: Reinforced Tapered Channel
Size: 193x61.5x6.0mm
Width: 753mm
Tensile Strength: 440 MPa

WHEELS & TYRES

Wheel - Type: 7, Single Piece Disc
- Size: 16x5.5K-115-9t
- Stud Pattern: 5x208mm PCD
Tyre - Size: 205/85R16LT 117/115L
Spare Tyre Carrier: Provided

OPTIONS

H56: 5600/8000kg GVM/GCM Rating
R36: Driver's Air Bag & Seat Belt Pre-Tensioner

MASS (kg - estimated)

Model	Front	Rear	Total
FE83DC4SRFAB	1680	675	2355
FE83DE4SRFAB	1695	685	2380

Note: Mass (est.) includes oil & water but excludes spare wheel, tools & fuel.

INSTRUMENTS

Gauges: Speedometer with Odometer & Dual Tripmeter
Tachometer
Fuel Level, Water Temperature
High Beam
Warning Lamps: Turn Signal / Hazard Warning
Park Brake / Brake Dual Circuit
Exhaust Brake, Low Vacuum, ABS
Engine Pre-Heat
Alternator
Low Oil Pressure
Engine Control (ECU)
Fuel Water Separator
Heated Mirrors
SRS Air Bag (R36 opt. only)

CAB FEATURES

All Steel Forward Control
Type: Manual Tilt 45°
Mounting: Hydroelastic 4 Point
Colour: Natural White
Interior: Fully Trimmed
Windscreen: Laminated Tinted
Windscreen Wipers: 2 Speed + Intermittent Cycle
with Integrated Washer Nozzles
Steering Column: Telescopic & Tilt
Rear Vision Mirrors: 1 x Internal, 2 x External Convex (ECE R46) - Heated
Seating Capacity: 3
Seat Belts: 2 ELR Lap Sash, 1 Lap
Seats - Driver: 228mm Sliding
47° Reclining
Headrest & Fabric Trim
- LH: Flat Folding, 2 Passenger Bench
LH Headrest & Fabric Trim

MAX. LOADING

Front	Rear	Total*
2300kg	3300kg	4500kg

*Optional 5600kg total loading.



1. New powerful, lower emission engine has 7% more power and 29% more torque* for even better performance. (*compared to ADR80/00 model)
2. Front and rear disc brakes with ABS provide superior stopping power and safety.
3. Spacious "not so squeezey" cab makes for an extremely comfortable mobile workplace.
4. Feature packed cab with dash mounted gear stick, air conditioning, CD player, power windows and keyless central locking. Driver's side airbag is optional.
5. Doors open wide for easier access to cab.
6. Supersize, heated, convex mirrors can fold flat against the cab.

SPECIFICATIONS

Typical Applications



STANDARD FEATURES

Driving

- Keyless Central Locking
- Electric Windows
- 12V Accessory Power Outlet / Cigar Lighter
- Air Conditioner / Heater / Demister
- Radio / CD Player
- Cup Holders (2)
- Interior Sun Visors
- Fluorescent Cabin Lamp
- Interior Dome Lamp with Delay Function
- Engine Idle Speed Control

Storage

- Dash Storage Tray, 2 DIN Glove Compartment
- RH Overhead Storage Pocket
- Door Storage Pockets
- Floor Console, LH Seat Back Trays
- Coat Hooks

Cab: External

- Roof Mounting Points (max. static load 50kg)
- Front End-Outline Marker Lamps
- Door Side Impact Beams
- Tinted Side & Rear Glass

Chassis

- Tool Kit
- Chassis Mounted Tool Box
- Reverse Warning Buzzer

DIMENSIONS (mm)

		FE83DC 4SRFAB	FE83DE 4SRFAB
Width	Front Fender:	1995	1995
	Rear Axle:	1936	1936
	Front Track:	1655	1655
	Rear Track:	1495	1495
	Frame:	753	753
	Max. Body Width - General Application:	2300	2300
Length	A Overall:	5200	6015
	C Front Overhang:	1145	1145
	D Wheelbase:	2750	3350
	G Front Axle to Rear of Cab:	525	525
	H Rear of Cab to Engine Cover:	50	50
	I Frame, Engine Cover to Rear Axle:	2175	2775
Height	J Frame, Rear Axle to End:	1265	1480
	P Cab to Ground:	2235	2235
	Q Cab to Frame:	1514	1514
	R Rear Frame to Ground:	810	810
Ground Clearance:		170	170

PERFORMANCE (Calculated - Paved Road)

Road Speed (km/h) at Max. Engine Speed:	124	124
Gradeability** at Rated GVM:	55.9%	55.9%
Gradeability** at Rated GCM:	28.0%	28.0%
Turning Circle (kerb to kerb):	10.2m	12.0m

**This is Theoretical Performance (it may vary under different conditions).



WARRANTY
Basic/Powertrain - 3 Years, 100000kms, 2000 operating hours:
and 3 Years Cab Perforation./Anti Corrosion.
* whichever occurs first.
See www.fuso.com.au for full details.

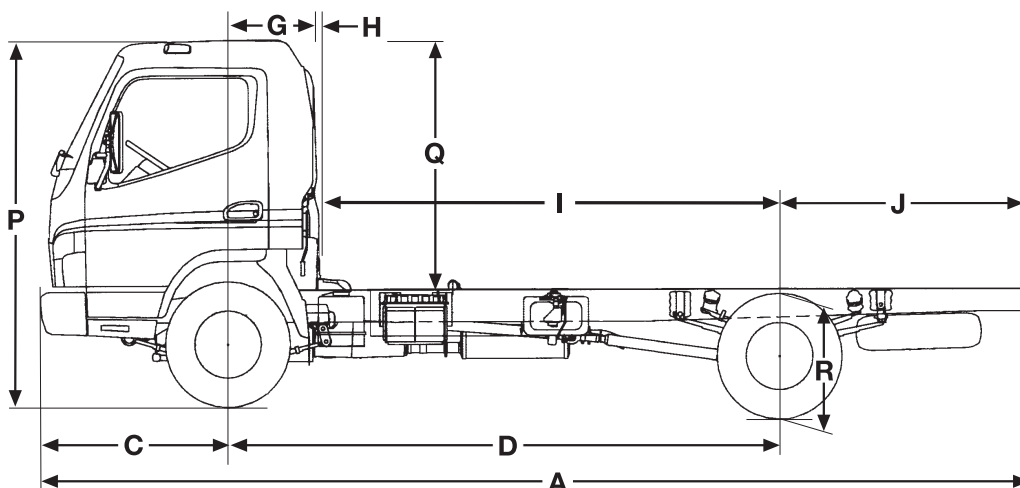

Note: Chassis reinforcement must be utilised for Tipper/Demountable type body configurations.

To conform with ADR 13/00 and 14/02 (lighting/mirror requirements) the following must be adhered to at body installation.

- If overall width exceeds 2.1 metres and other than a flat type or tipper body is fitted, rear end-outline marker lamps must be installed.
- If overall length exceeds 6.0 metres, side reflectors must be installed.
- If overall width exceeds 2.1 metres and length exceeds 7.5 metres, side marker lamps must be installed.
- If overall width is less than 2.2m, the mirrors must be modified to project not more than 230mm.

To conform with ADR 42/04 (General Safety), rear wheel guards must be fitted to the vehicle.

Unless specified in writing herein the accessories, applications, bodies or equipment depicted in this document are for illustration purposes only and may not be available from Mercedes-Benz Australia/Pacific Pty Ltd (ABN 23 004 411 410) ("MBAuP"). No representation or warranty whatsoever is given in relation to any accessories, applications, bodies or equipment or suitability of same that are shown herein that may be manufactured, supplied or fitted by a party other than MBAuP. MBAuP reserves the right without notice or obligation to discontinue or make changes to the colour, designs, materials and specifications of the products and options referred to herein at any time. For the most current information and in order to ascertain which accessories, applications, bodies and equipment are available from MBAuP please contact your authorised Mitsubishi FUSO truck and bus dealer. Fuso is a registered trademark of Mitsubishi Fuso Truck & Bus Corporation. Copyright © MBAuP. Reproduction in whole or part prohibited without written approval.

Date: Apr.'09 Part No. TSC10A

