

Maxi-CUBE

Classic Dry Freight



The Maxi-CUBE Classic

For 30 years, Maxi-CUBE has lead the Australian temperature controlled transport market in product innovation, providing its customers with reliable, high payload, high volume, thermally efficient vans that deliver profits to their owners.

Some Maxi-CUBE Options to suit your needs

- Various lengths and heights available to order
- Disc brakes
- Aluminum on hardwood floors
- Fibreglass rear infill panel
- Drop Deck
- Belly lockers
- Maxi-CUBE double loader system
- Roller doors
- Side doors
- Powered tailgate loader

*Photo for illustrative purposes only.

Classic Dry Freight Specifications

(Nominal and Typical)

Dimensions

Length	(22/24 pallet) 13730mm / 14700mm (45/48ft)
Overall Height	4300mm
Skidplate Height	1270mm
Kingpin Location	1500mm from front
Suspension Location	Up to 9500mm from kingpin

Body

Roof	Single skin opaque fibreglass
Side Walls	17mm FRP/plywood panels
	Polished aluminium body rails
Floor	Hardwood
Front Wall	Fibreglass/Ply panel
Rear Doors	FRP/Ply panels & anti-rack double lock rods
Rub Strip	External - 1 piece aluminium extruded
Scuff Band	Internal - 1 piece aluminium extrusion
Rear Frame	Fabricated galvanised steel

Frame

Crossmembers	Steel
Bumper	100mm square steel
Skidplate	8mm with 50mm bolt-in kingpin

Brakes

S' Cam	A.D.R. 38.
	Male and female couplings at front.

Underbody

Tyre Carrier	1 Standard. Rigid 2 wheel Galvanised
Tool Box	Standard

Electrical

Voltage	Multi-volt to A.D.R. 13 (exterior lighting)
Lamps	LED Multi-volt
Interior	3 - roof mounted (12 volt)
	Twin electrical plugs at front

Landing Gear

Rocker Foot	2 speed
-------------	---------

Paint

Exterior	White gelcoat. Interior - Blue gelcoat.
Underside	Silver or galvanised.

Mudguards

	Extruded aluminium splashguards with flaps fitted to rear of suspension group.
--	--

Suspension

	Tri-axle air bag
--	------------------

Axles

	Maxus 10 stud
--	---------------

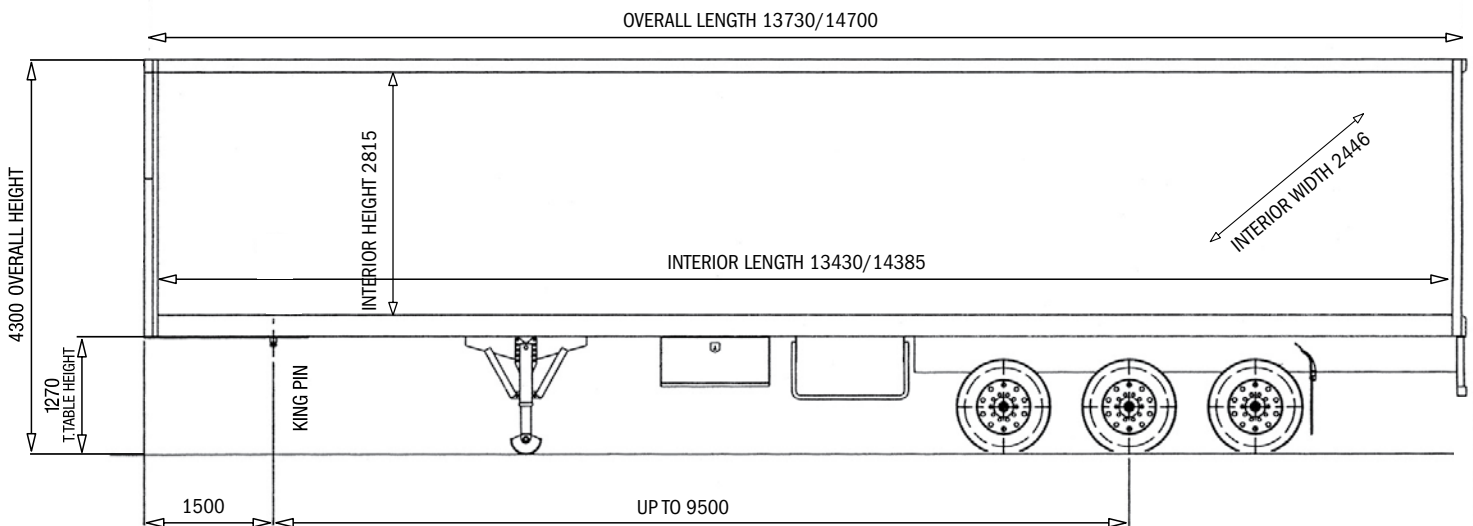

Note: interior width is nominal based on width between walls
interior height based on t/table height of 1270mm

Maxi-CUBE

Classic

www.maxicube.com.au

MaxiTRANS Aust Pty Ltd
Victoria (03) 8368 1111
Western Australia (03) 8368 1111

SX Trailers
NSW (02) 9755 3333
Mildura Truck Centre
Sunraysia (03) 5051 2800

CMV Trailer Sales
SA (08) 8139 4000
Western Diesel NT
NT (08) 8935 9100

Freighter Maxi-CUBE Qld
QLD (07) 3277 5511
MaxiTRANS New Zealand
Auckland (09) 269 0712

Disclaimer: MaxiTRANS provides the information contained herein in good faith, based upon information current to date. MaxiTRANS reserves the right to change specifications without notice. However, MaxiTRANS accepts no liability, either direct or indirect, for any loss or consequential loss that may result from the application of this information. Purchasers must conduct their own enquiries to ensure that the products are suitable for their own particular purposes. Any comments made regarding products and construction are made on an informative basis, not as a recommendation. Some features shown may be optional.
Classic™ and Maxi-CUBE are registered to the MaxiTRANS Group. MaxiTRANS Australia Pty Ltd. ABN 95 081 151 699.